



Portfolio – Restaurant Design Services



SrinSoft Inc, Partners of

Autodesk
Authorized Developer

PTC[®]

SOLIDWORKS

Microsoft
CERTIFIED
Partner

Overview

Olilo has end to end expertise in designing restaurants ranging from concept design all the way through designing equipments. We create the most impressive, timeless, solution-oriented restaurant design.

Olilo has a team of experienced Engineers, Architects and CAD experts, who work with contractors and product manufacturers to produce highly accurate construction drawings, CAD models and visualizations using Building Information Modeling (BIM) technology.

Our team also creates world-renowned kitchens equipments, providing a more productive work environment and contributing to back-of-house profitability. We understand how to design a practical restaurant kitchen that not only looks sensational and is totally practical for day-to-day operations, but minimizes build out and construction costs.

Restaurant Design Services

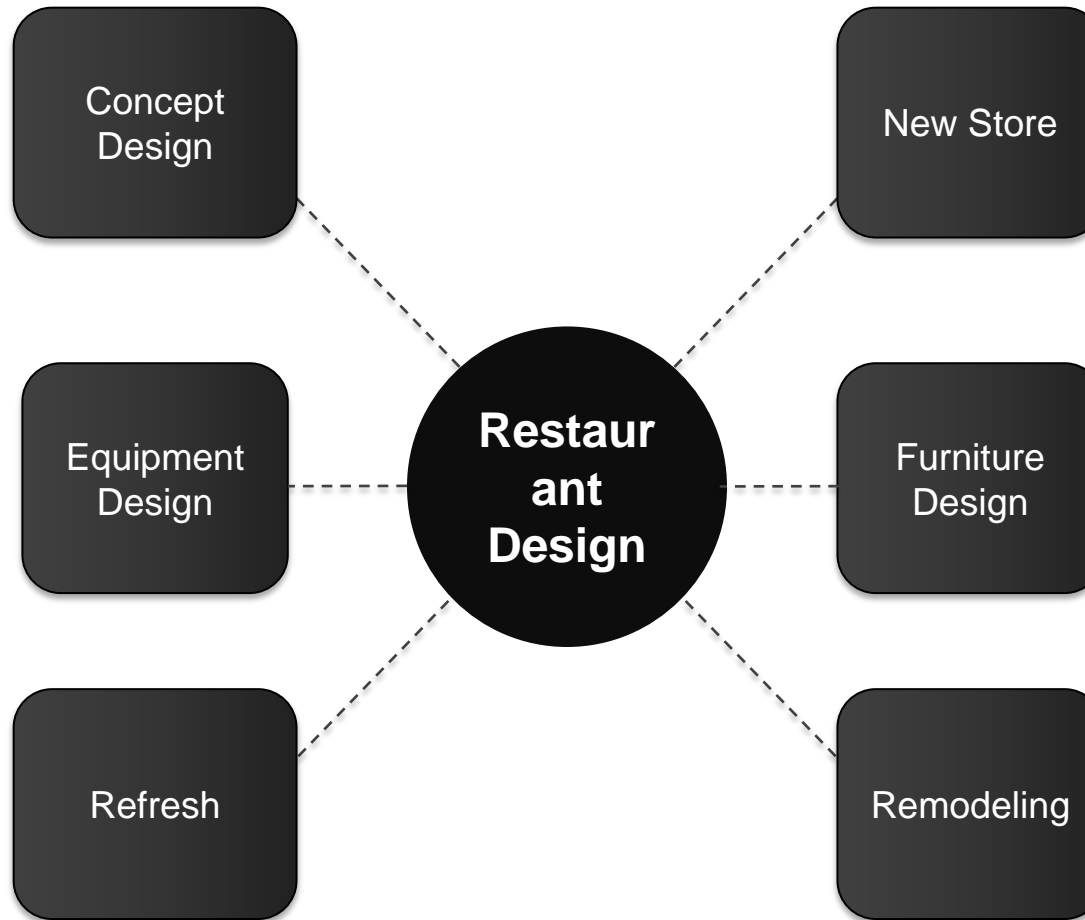

Presentation Services

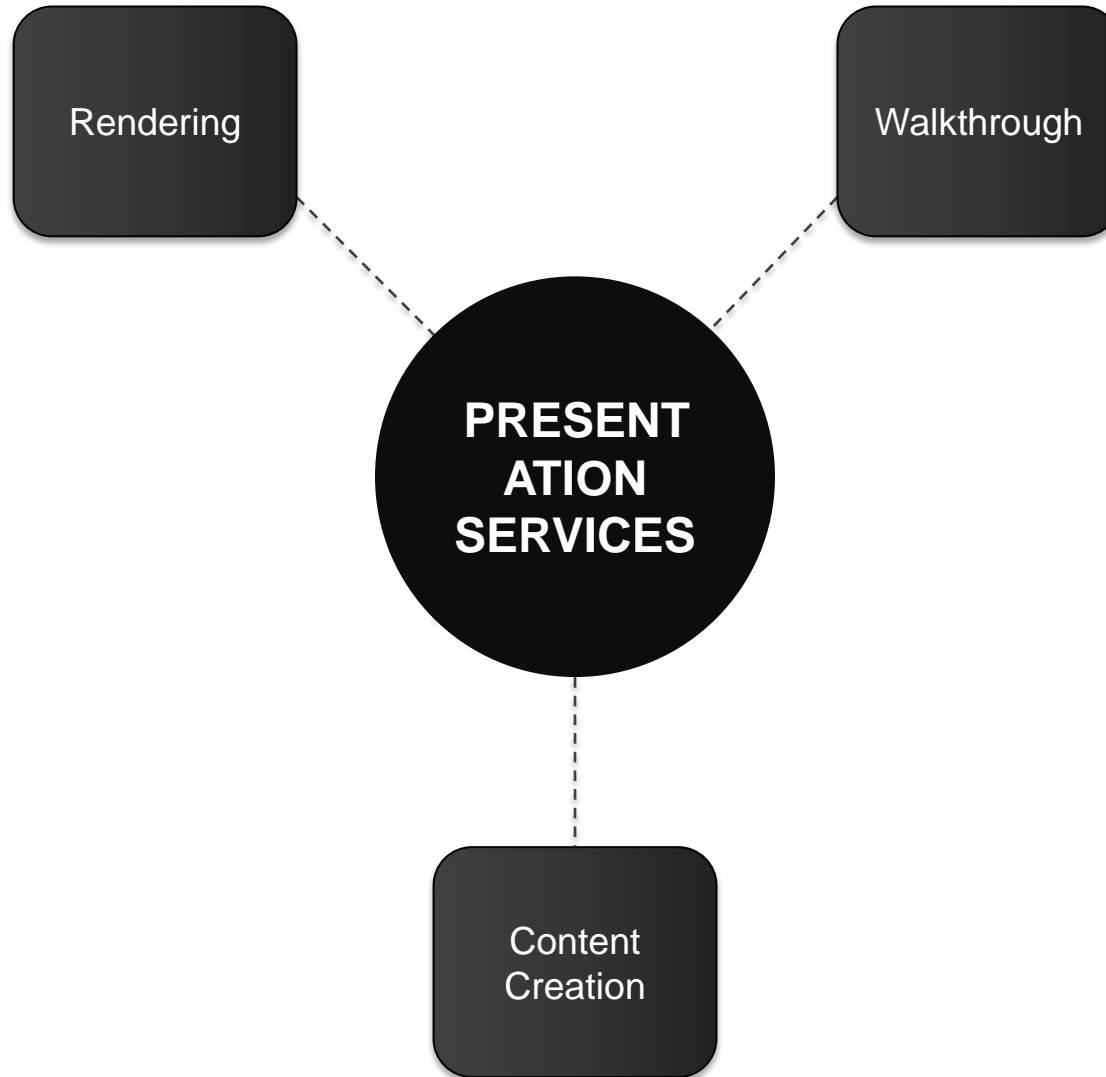

Engineering Software Expertise

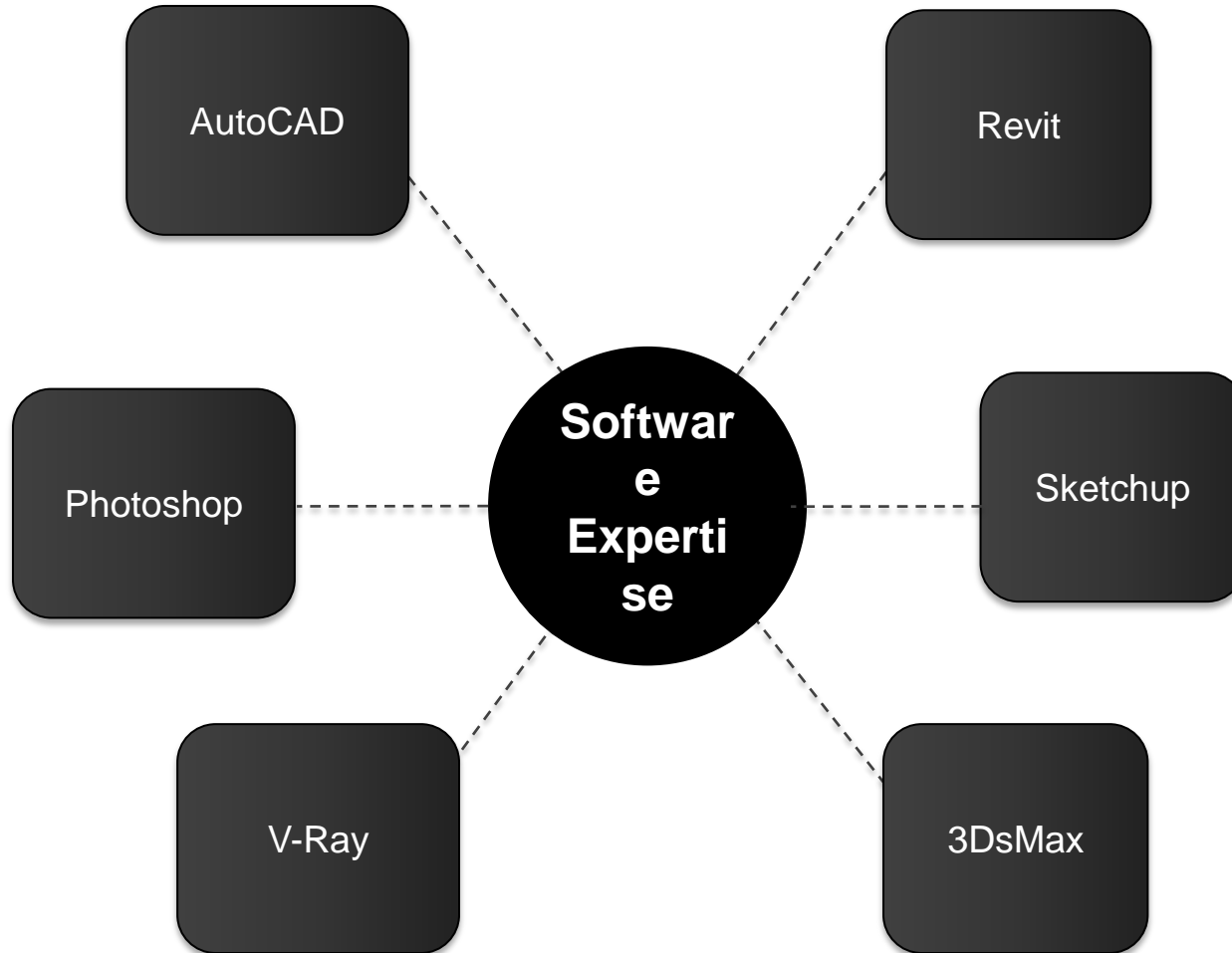

Product Design

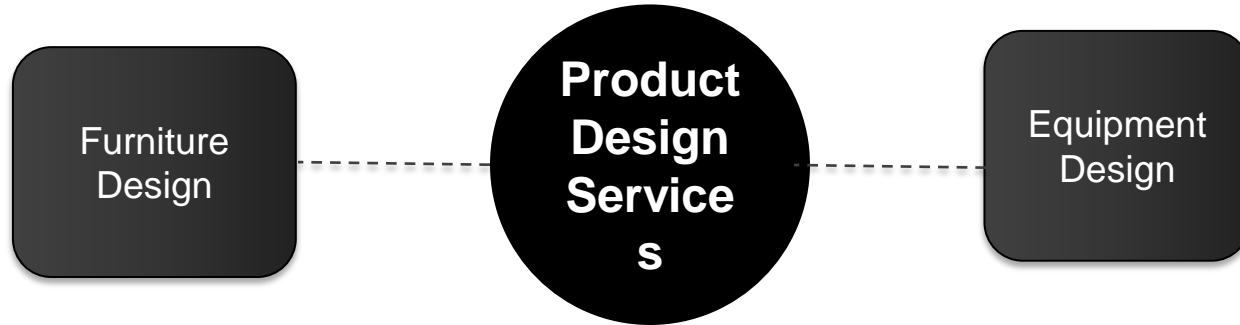

Automation Expertise

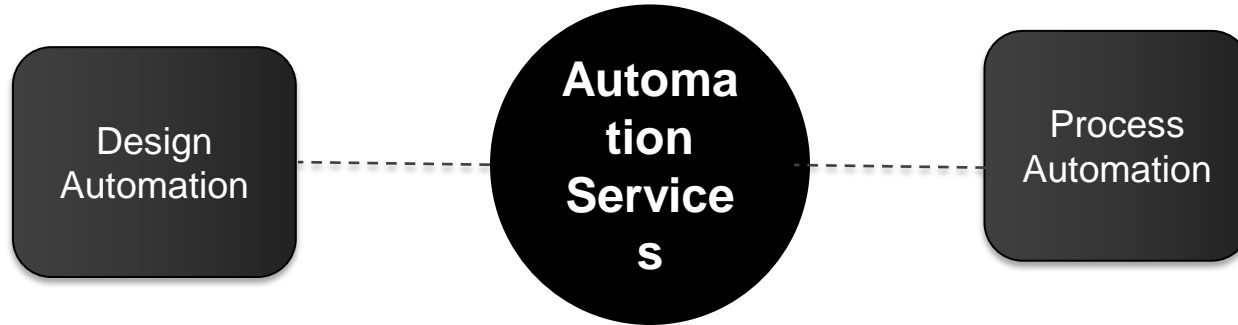



Restaurant Design

Concept Design

Design concept is the primary logic behind the design. Our designers study and understand the space to think about the concept and create a framework for how the space should be.

Conceptual descriptions set at the early stages of the design process are used to frame some general design approach. Interpreting the output of the design action confers meaning on the concepts. Conceptual frameworks can assist in setting boundaries and framing reasonable objectives.

Olilo's Approach

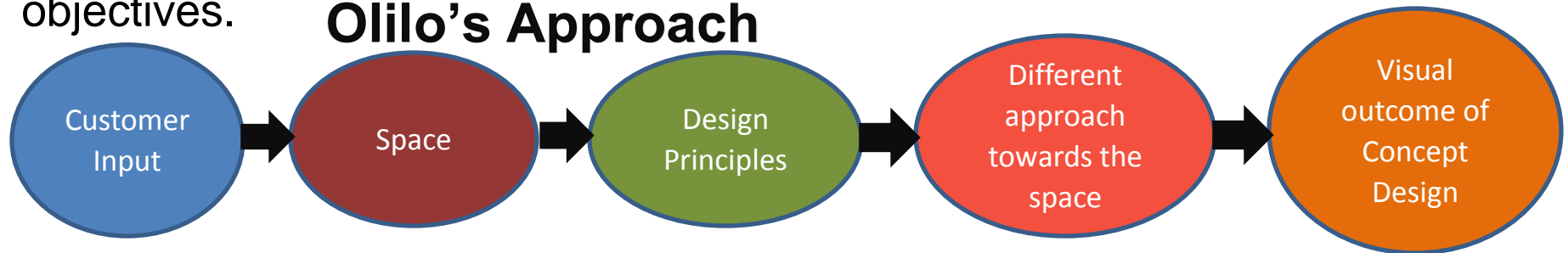

- Primary Logic behind the design
- Satisfy the needs of our customer
- Solving current Issues

Concept Design

Main Dining View



Que Line View



New Store Design

New store design, Architectural design of the project is developed and defined in detail sufficient to illustrate via plans, sections, elevations and 3D imagery, the overall form and fabric of the project and its detailed layouts, spatial arrangements, facades, overall appearance and range of construction materials and finishes.

New store design satisfies the needs of customer in cost, aesthetic, construction material, Specifications and in design standards.

Olilo's Approach

- Providing numerous options in Design.
- Providing Design elements and Furniture finishes for Aesthetic.
- Cost Effective & Meets the Budget of the customer.

New Store



Remodel Design

Remodel Design adding value to an existing store. Designers will try to utilize the existing resource and then choose the best remodel design to the store as per the recent trends and also to meet the customer's budget.

Remodel designs are illustrated via plans, sections, elevations, specifications and 3D imagery.

Olilo's Approach

- Refurnishing the store
- Adding value to the store
- Providing new finishes and Design elements as per the customer needs

Remodel Design

Before



After

Refresh Design

Refresh Designs branding the store which involves brightening the finishes, changing the graphics and signage.

Refresh design stores are Eye-catching by providing bright Informatory graphics.

Olilo's Approach

- Branding the store
- Make the store lively and new
- Furniture finishes blend well with the existing store
- Cost effective

Refresh Design



Space Planning

In space planning, the design professional blocks out interior spatial areas, defines circulation patterns, and develops plans and layouts for furniture and equipment placement.

Space allocation criteria, building codes and access for the disabled, furniture standards, circulation and work flow, design considerations, the constraints of fixed building elements and flexibility for accommodating future space needs are considered in space planning.

Olilo's Approach

- Implementing the Furniture layout effectively
- Key elements – Clearance, Target seating capacity, Functional Criteria
- Manage space guidelines

Space Planning



Before



After





Product Design

Product Design

The major challenge in presenting the restaurant area with all possible type of equipments is how it is designed to equip and present it when needed.

Olilo has expertise designing restaurant equipments like:

- Furnitures
- Refrigerator
- Cleaning system
- Food storage cabinets
- Dish tables
- Sinks
- Preparations tables
- Shelves
- Food Counters, etc.

Our team is capable of designing any kind of restaurant equipment with complex design requirements with the best quality.

Furniture Design

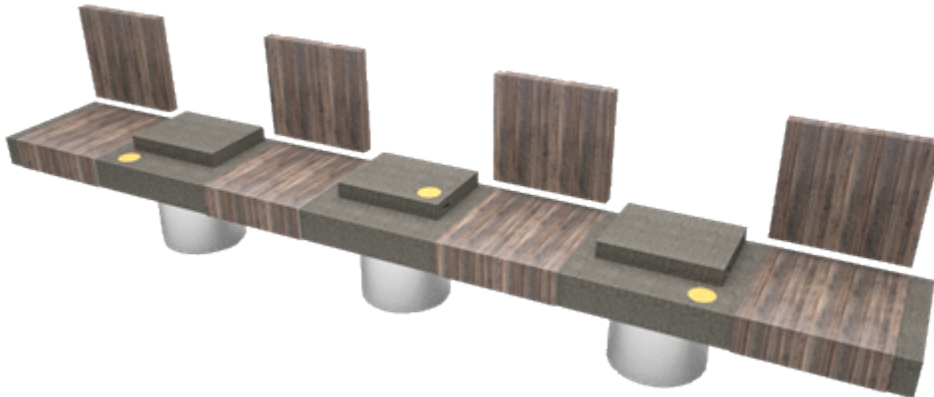
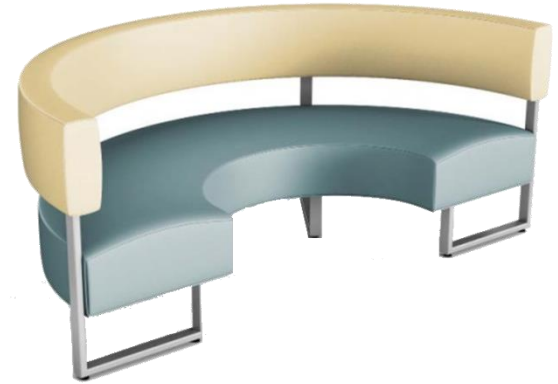
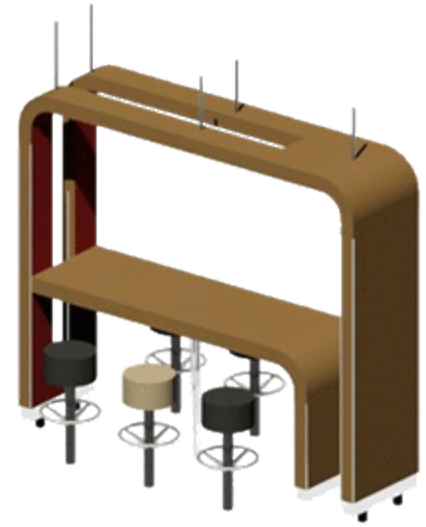

Equipment Design

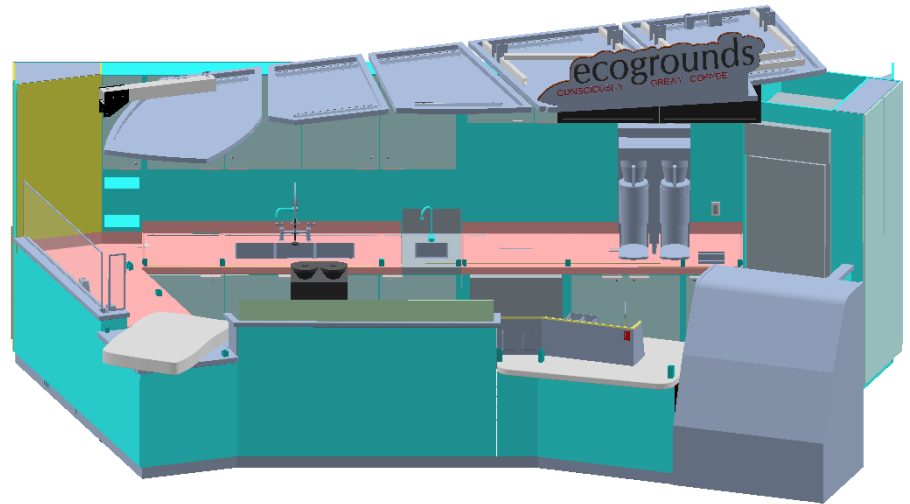
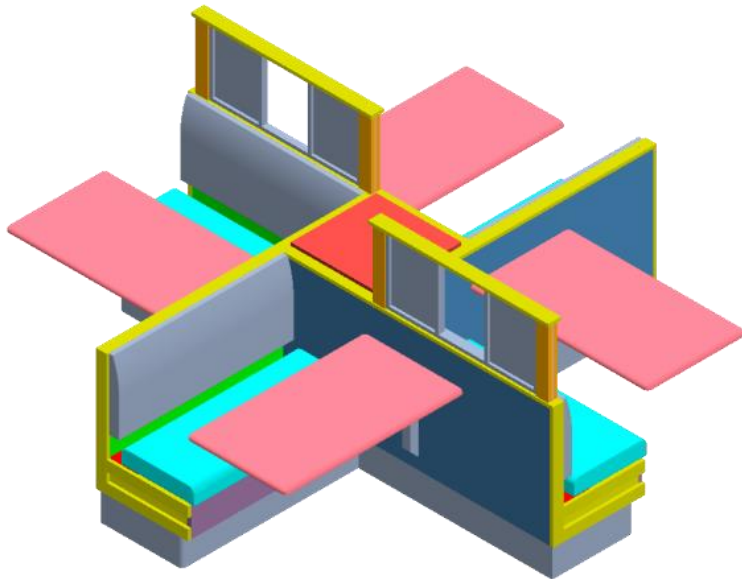
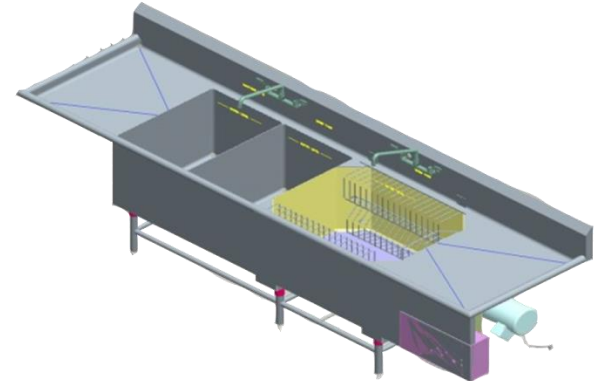
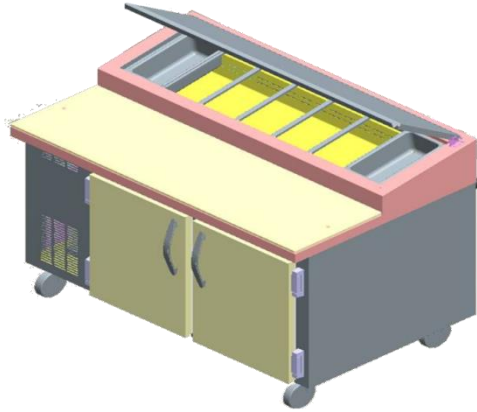
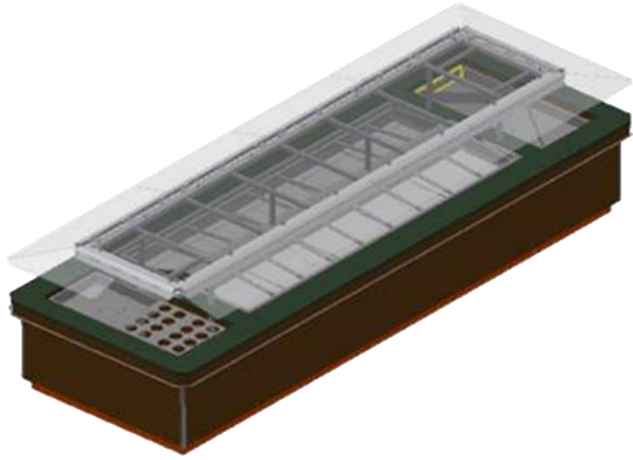

Equipment Design

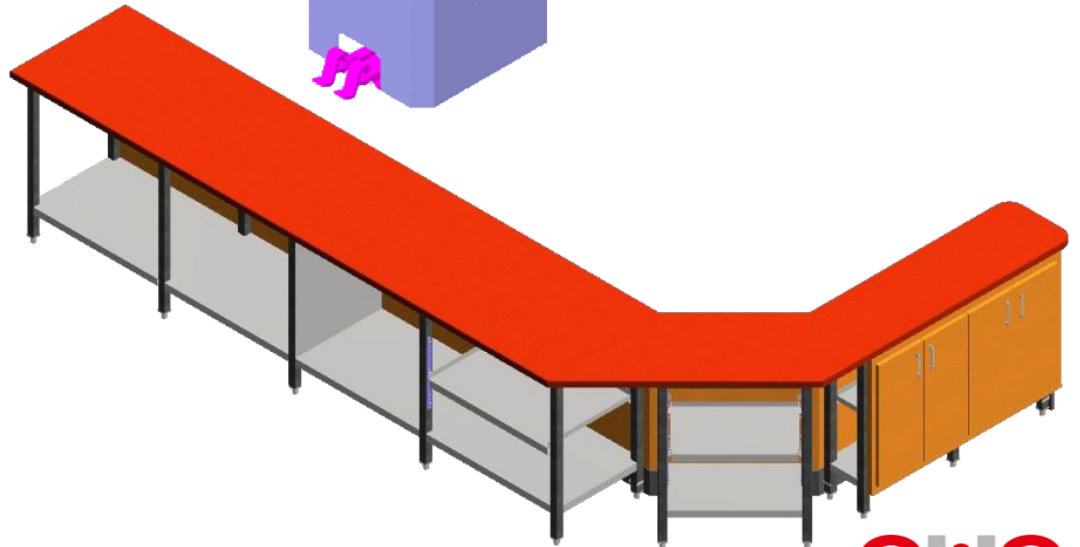
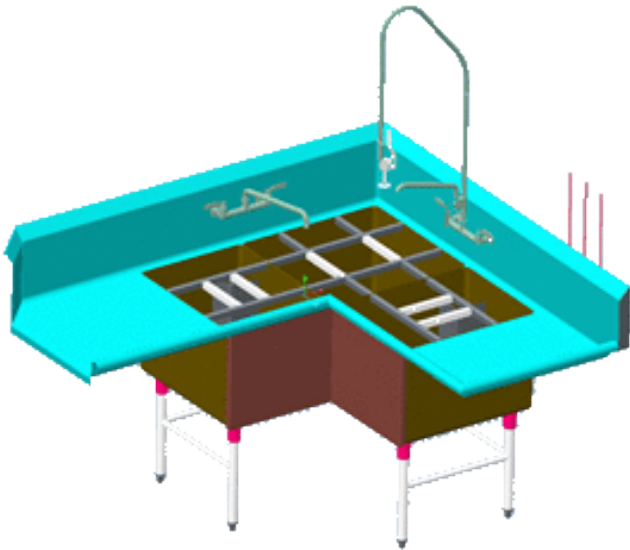
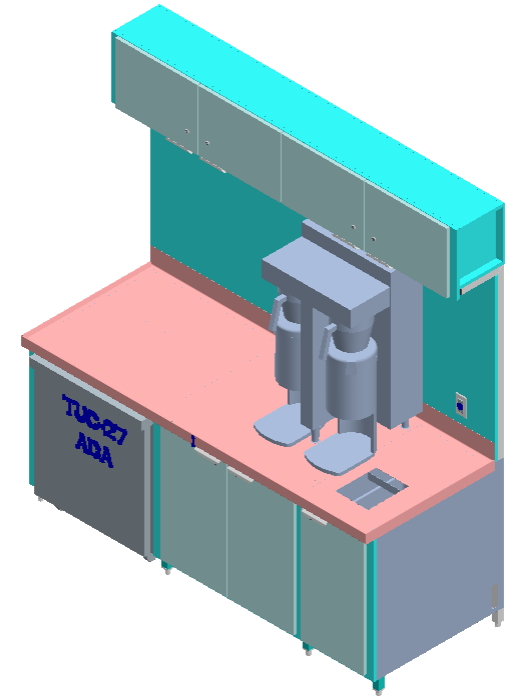
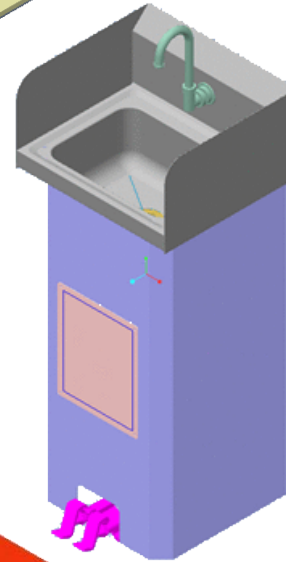
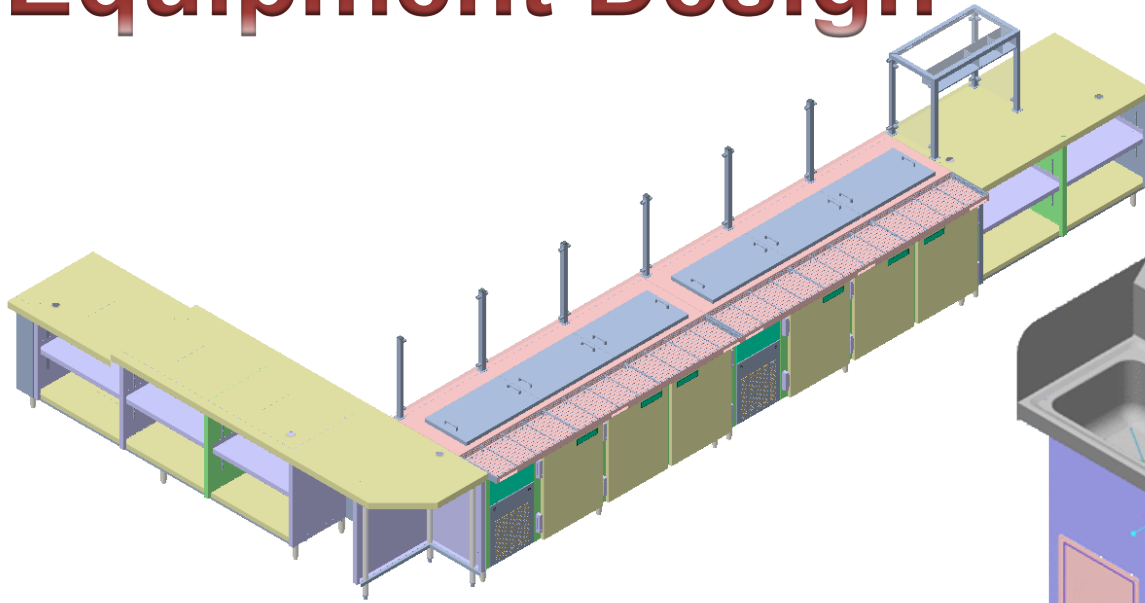



Presentation Services

Rendering & Walkthrough



Content Creation

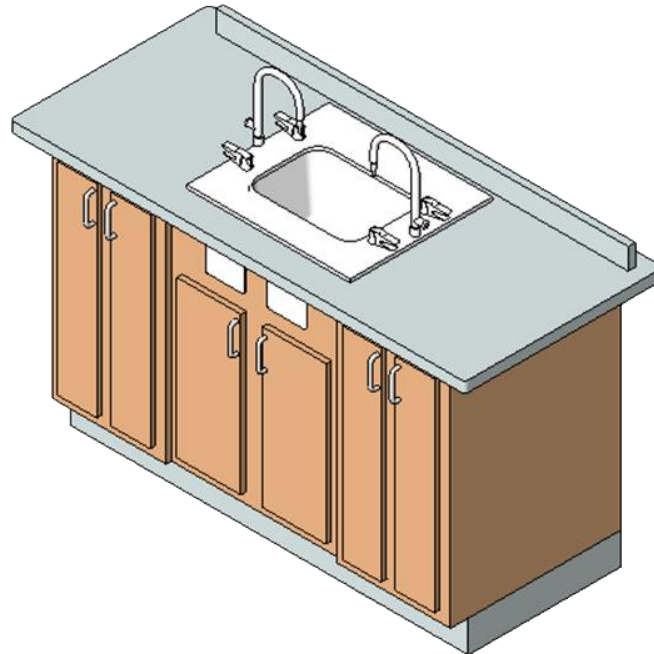

Content Creation

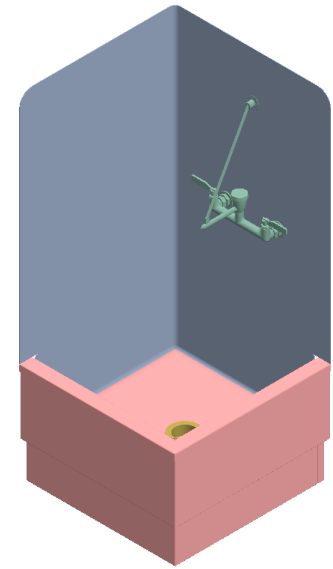
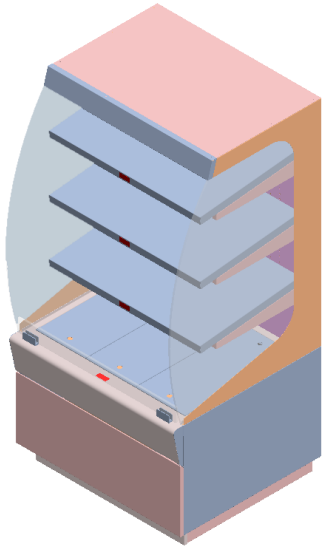

Content Creation

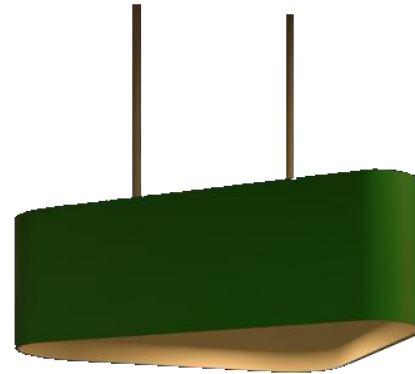
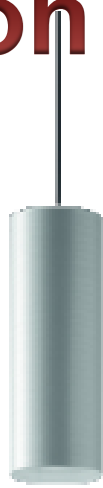

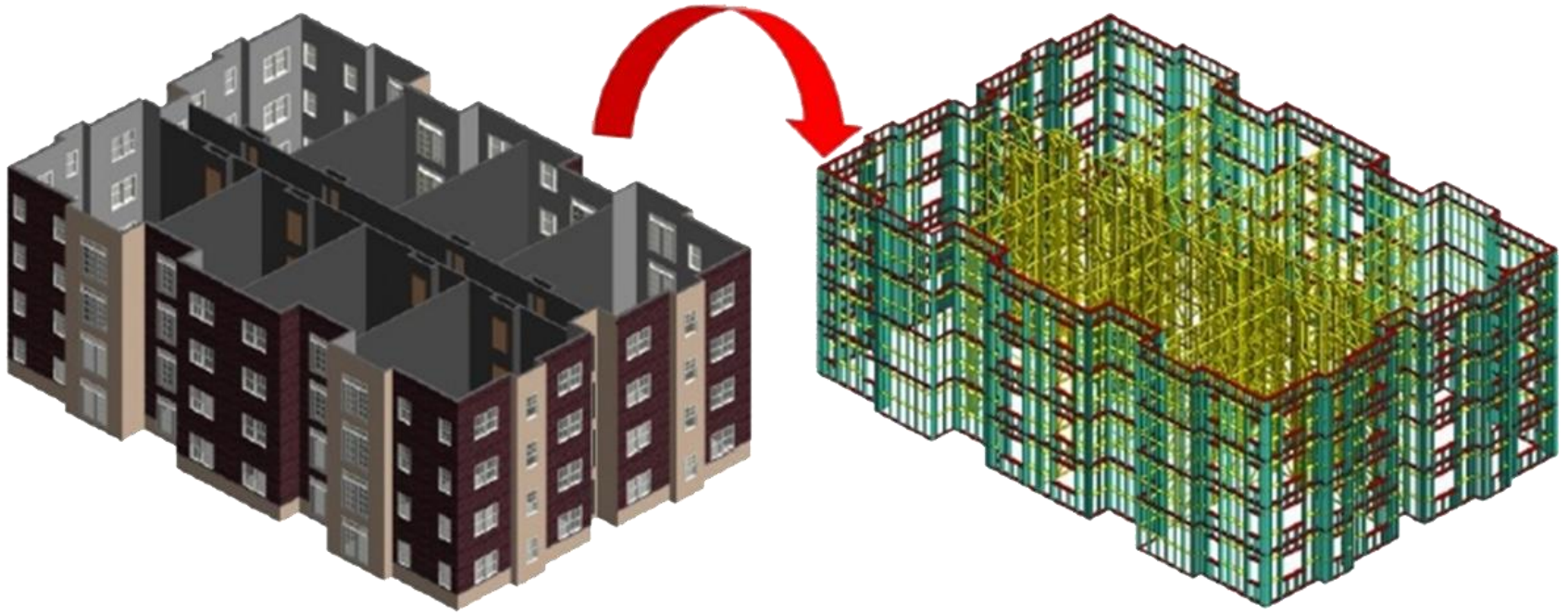

Automation Services

Design Process Automation

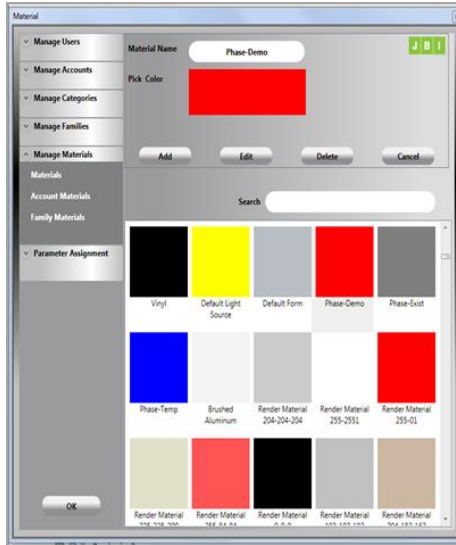
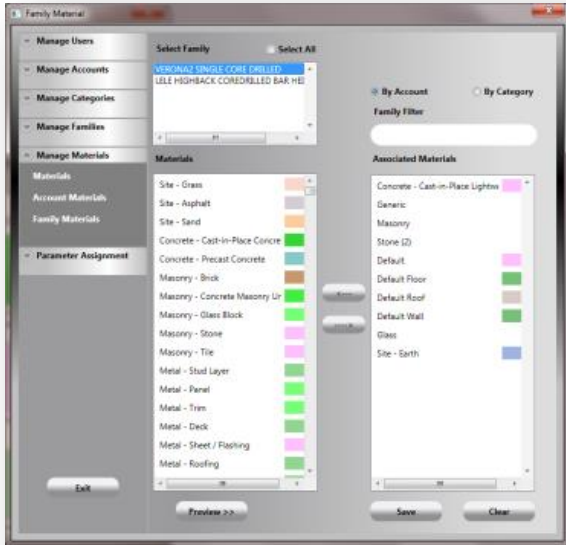

Web Server

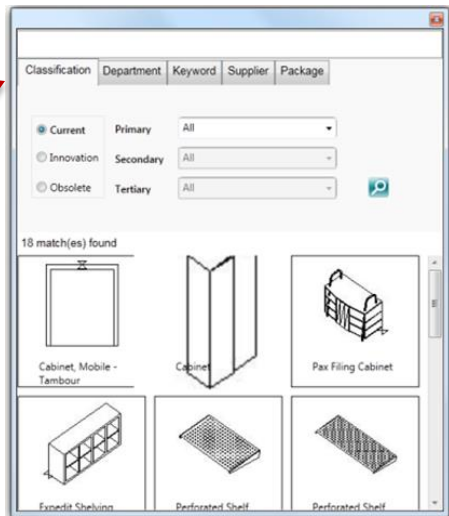

Schedule Number: 1 SCHEDULE

Schedule To:	Ship To: STATE HIGHWAY 27 OKEMAH, OK	Project ID: L-MCDB97
		Schedule Date: 10/14/2011
		Terms:
		Project Consultant:
		Cont ID:

NOTE: ALL QUANTITIES DESCRIPTIONS, DIMENSIONS, MATERIALS & FINISHES MUST BE VERIFIED. STANDARD GRADE MATERIALS AND FINISHES ARE SCHEDULED UNLESS OTHERWISE NOTED. PRICES ARE SUBJECT TO CHANGE UPON VERIFICATION.

Line	Description	Item I.D.	Qty.	Unit Price	Item Price
1	VERONA2 DOUBLE CORE DRILLED 42" Standard height Length_17x42"Width-42" Materials: Back Panel Color_L_SPC3 PA-AsiCom Shimmer AC9223 6 Perforation_PA8000 Steel Color_SPC19 AsiCom Shimmer AC9223 6 Perforation_PA8000 Support Color_SUC PG-Steelless Steel 4_SPC504	BT-4	2	\$300.00	\$600.00
2	VERONA2 SINGLE CORE DRILLED 80" Standard height Length_17x80"Width-24" Materials: Back Panel Color_L_SPC3 PA-AsiCom Shimmer AC9223 6	BT-6	1	\$100.00	\$100.00

Design Process Automation

- Design process automation based on specific customer account
- Custom design environment for designers including design standards, families, materials
- Admin setup to define user environment as per specific account
- Interface with ERP to fetch data required for design like cost estimation, stock availability, lead time etc.
- Custom report generation based on specific customer account
- Web based centralized content management system for various custom families for designers
- This tool communicates with web server and provide drag & drop interface where users can pull the families into Revit for modeling based on various search criteria
- Quality Control check process for based on custom standards

Steel Framing Automation

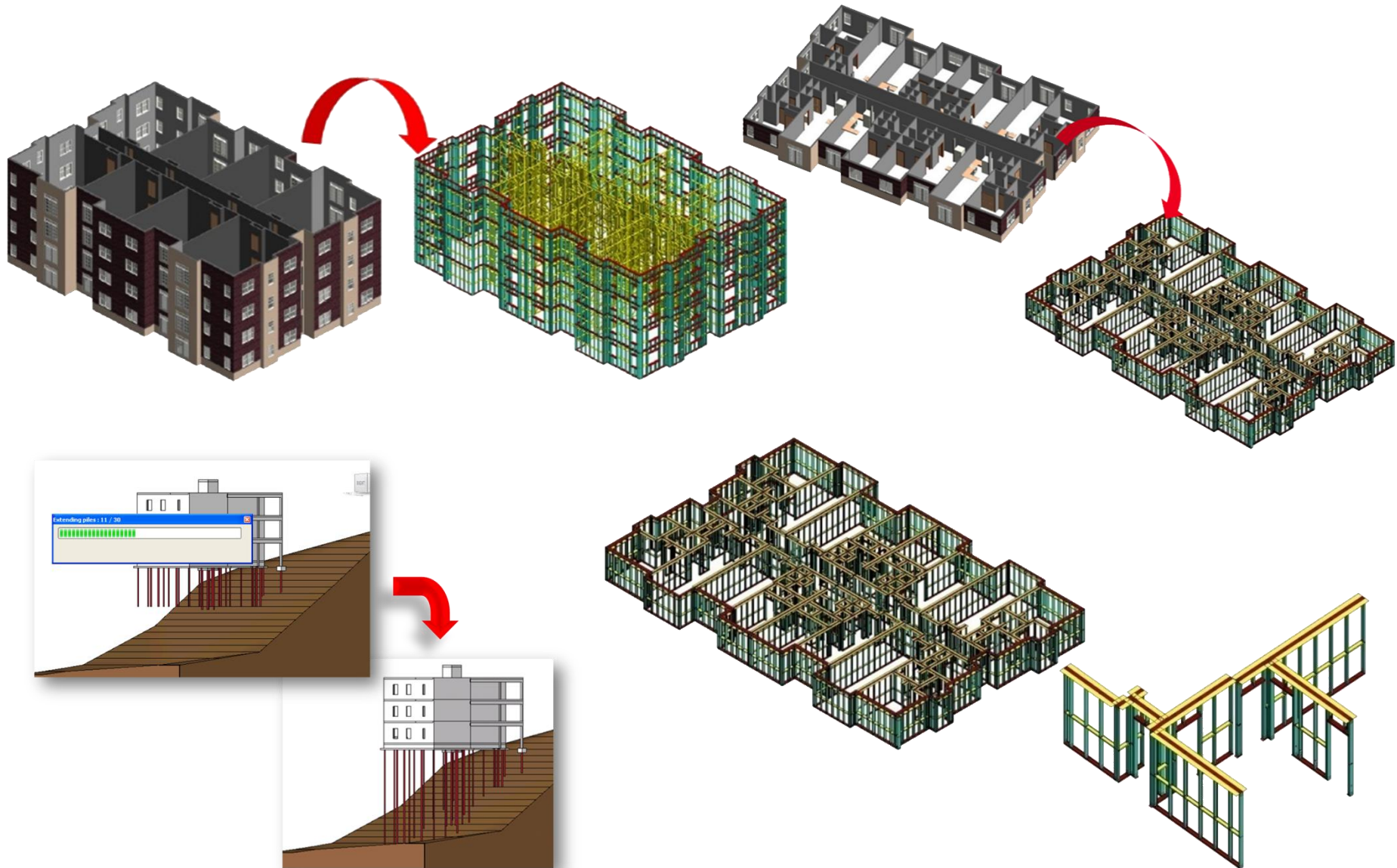





Steel Framing Automation

- This application uses Rosette System of manufacturing to panelize Cold Formed Steel (CFS) structures
- These sustainable structures are meant for areas which are exposed to severe weather and/or seismic activities
- This application can be used to frame High Rise as well as Mid Rise buildings
- This application automates the framing of all types of floors, walls, roofs, trusses & MEP installations including structural connections
- The structural framing plans, Bill of Materials & CNC data of all panel frames are generated automatically
- Automatic shop drawing generation in Inventor
- Automatic Structural analysis with interface to Staad.Pro
- Add-on tool to automatically extend structural piles to topographic

Web Based Knowledge Management

Welcome Asif 

 Home |  Notification |  Favourite |  Tag |  Add

Reference Guide

 Search

Index

- Service Area
 - Fast Forward
 - Modular FSC
 - Split FSC
 - MCCAFE Extension
 - SEEQ**
 - Create Your Taste
 - Hiring To Win
 - CBB
 - Kitchen
- Crew Room
- Play Place
- Regional Rules
- Project Types
- Electrical
- Element Details & Finishes & Lighting
- MCD'S Process
- Project Presentations
- PortFolios
- ADA
- Graphics
- Additions
- Perimeters
- Drawing and Template Updates

SEEQ - Simple Easy Enjoyment Queue



Introduction

Simple Easy Enjoyment Queue

McDonald's asked our team to bring their brand promise of "Simple, Easy Enjoyment" to life in retail through one harmonious voice. We started with the basic understanding that people eat with their eyes first, and that the first and most meaningful contact with consumers is the point of order. Our solution in redesigning the entire ordering process increases the brand's quality perception through easier menu navigation, and photography that highlights the food's preparation and the moment before it is eaten. 'SEEQ' is the official design standard for new McDonald's stores in 2011.

Description

The client wanted us to bring McDonald's brand promise – simple, easy enjoyment – to life beyond the efficient operations they are famous for. We worked with the client to identify opportunities to fully realise McDonald's brand promise from the moment our guests walked into the door. The first tangible and meaningful contact with the brand occurs at the time of order

Simplify and reduce clutter/confusion during the ordering process.

- Harmonise front counter with dining room décor packages.
- Design architectural homes for merchandising along the customer purchase path.
- Increase brand quality perception through easier menu navigation

Reference

[PortFolio](#)
[Guidelines](#)

Key Clientele

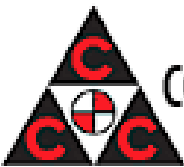

CONSOLIDATED CONTRACTORS COMPANY

JOHN ZINK



iSi Interior Systems, Inc.



LS² Consulting

UBM



WESTIN
HOTELS & RESORTS



Gensler

COMMScope

WorkLogix

Thank You